

# Art. 2MEXR

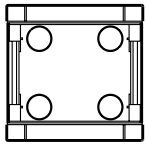

MD71

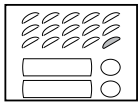

MD12

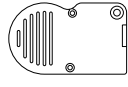

MD30

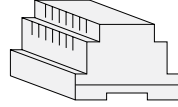

PRS240

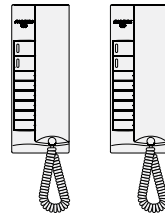

2 x EX320R

**IT** Installazione della pulsantiera  
**ES** Instalación de la placa de calle

**EN** Installation of the push-button panel  
**PT** Instalação da botoneira

**FR** Installation de la plaque de rue  
**DE** Installation der Türstation

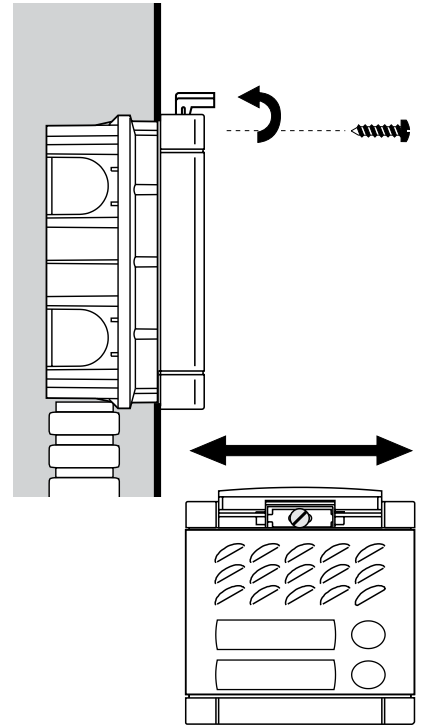
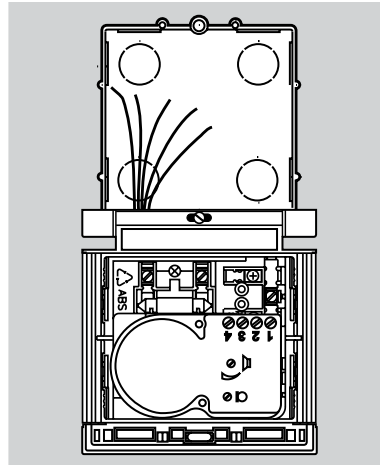
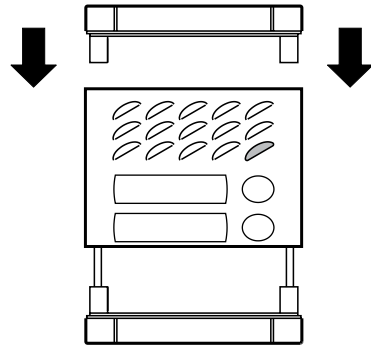
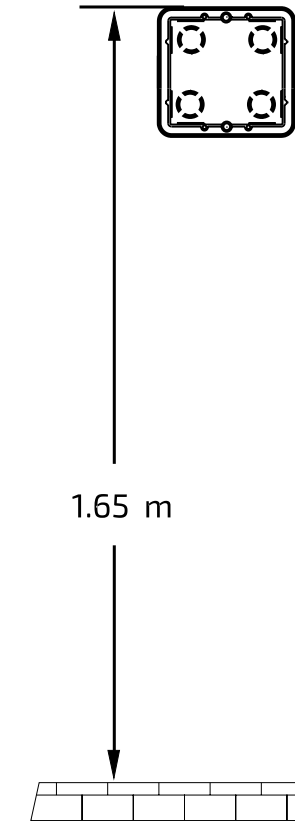
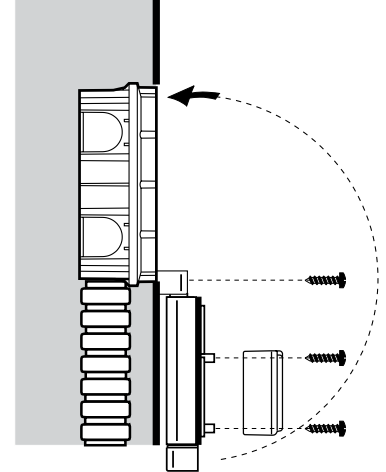
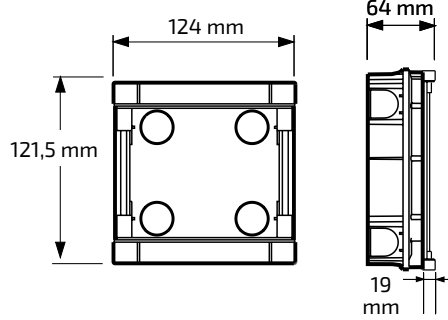
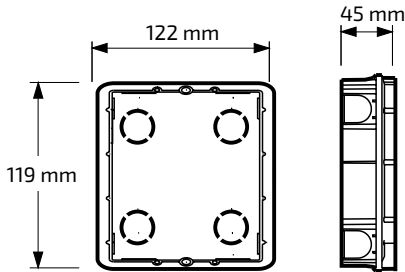

**IT** Installazione del citofono  
**ES** Instalación del teléfono de portero

**EN** Installation of the intercom  
**PT** Instalação do telefone de porteiro

**FR** Installation du combiné  
**DE** Installation der Gegensprechanlage

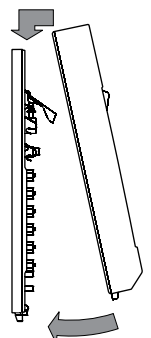
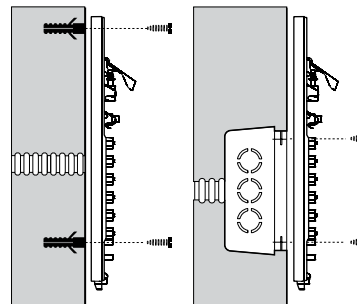
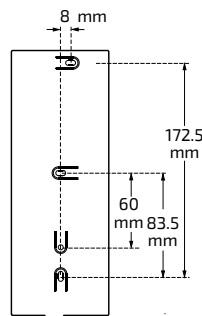
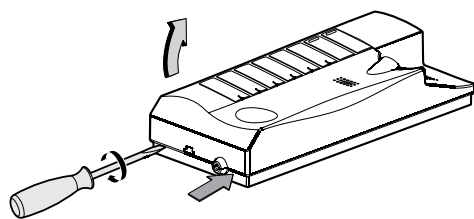

**IT** IMPIANTO CITOFONICO BIFAMILIARE  
**EN** TWO-WAY INTERCOM SYSTEM  
**FR** INSTALLATION INTERPHONIQUE À DEUX DIRECTION

**ES** INSTALACIÓN DE PORTERO BIFAMILIAR  
**PT** INSTALAÇÃO DE PORTEIRO BI-FAMILIAR  
**DE** SPRECHANLAGE FÜR ZWEI FAMILIEN

ITALIANO

ENGLISH

FRANÇAIS

ESPAÑOL

PORTUGUÊS

DEUTSCH

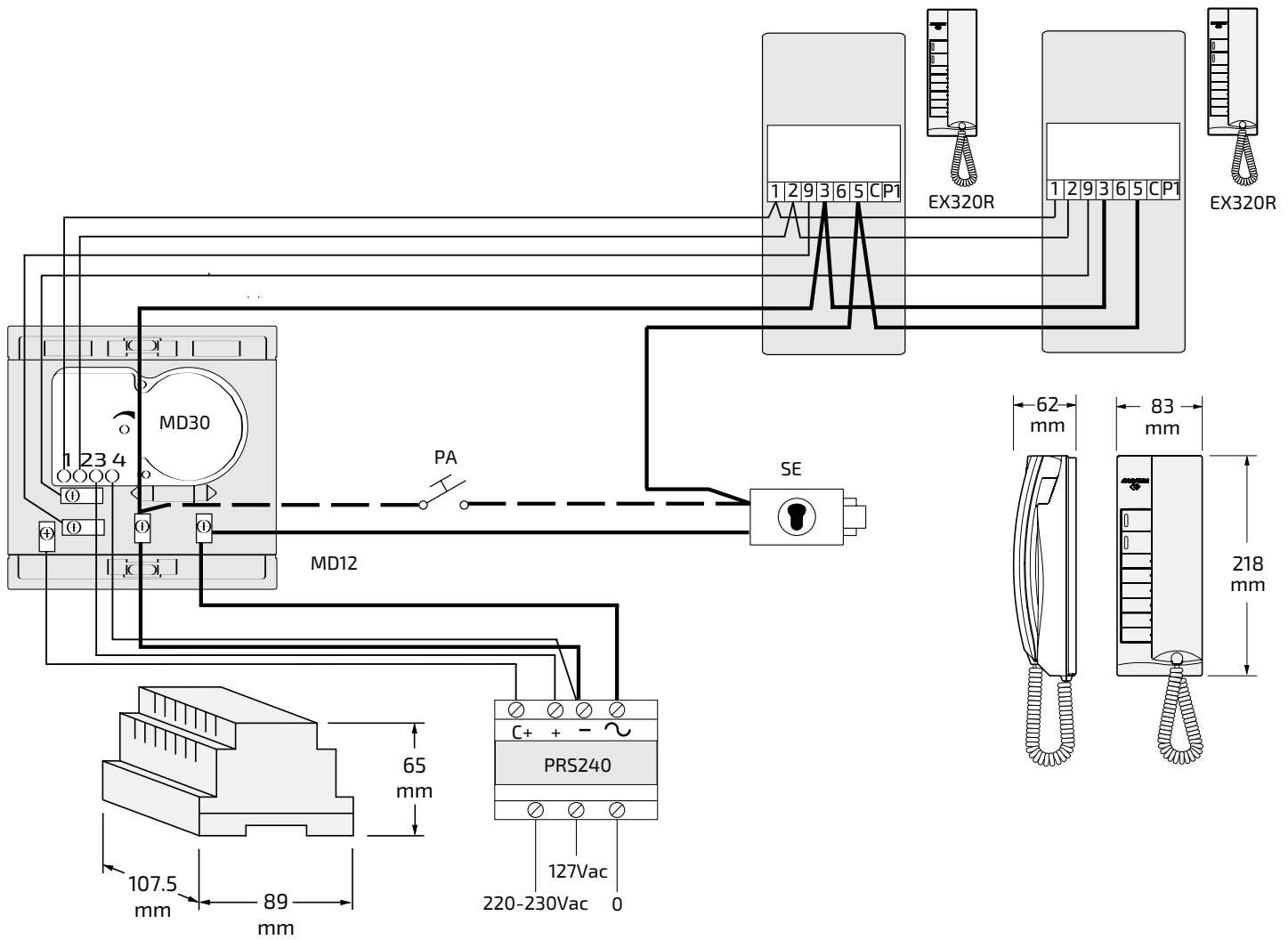

- PA** = Pulsante apriporta (opzionale)  
*Door release push-button (optional)*  
 Bouton-poussoir ouvre porte (optionnel)  
*Pulsador abrepuerta (opcional)*  
 Botão para abrir a porta (opcional)  
*Türöffnertaste (optional)*
- SE** = Serratura elettrica (12Vca-1A max.)  
*Electric door lock (12VAC-1A max)*  
 Gâche électrique (12Vca-1A max)  
*Cerradura eléctrica (12Vca-1A máx.)*  
 Fechadura eléctrica (12Vca-1A max)  
*elektrisches Türschloss (12VWs-1A max)*

m.	1, 2, 9, C+			3, 5, -, ~		
	S mm <sup>2</sup>	Ø mm	AWG	S mm <sup>2</sup>	Ø mm	AWG
50	0,35	0,6	22	0,75	1	18
100	0,35	0,6	22	1	1,2	16
200	0,5	0,8	20	2	1,4	14
300	0,75	1	18	2,5	1,8	13
400	1	1,2	16	-	-	-

**Directive 2012/19/EU (WEEE-RAEE)**  
 Smaltire il dispositivo secondo quanto prescritto dalle norme per la tutela dell'ambiente.  
*Dispose of the device in accordance with environmental regulations.*  
 Écouler le dispositif selon tout ce qu'a été prescrit par les règles pour la tutelle du milieu.  
*Eliminar el aparato según cuánto prescrito por las normas por la tutela del entorno.*  
 Disponha do dispositivo conforme regulamentos ambientais.  
*Werden Sie das Gerät in Übereinstimmung mit Umweltregulierungen los.*

Mi2537/1  
 Cod. M527056510

**ACI srl Farfisa Intercoms** Via E. Vanoni, 3 • 60027 Osimo (AN) • Italy Tel: +39 071 7202038 (r.a.) • Fax: +39 071 7202037  
 e-mail: info@farfisa.com • www.farfisa.com

La ACI Srl Farfisa Intercoms si riserva il diritto di modificare in qualsiasi momento i prodotti qui illustrati.  
 ACI Srl Farfisa Intercoms reserves the right to modify the products illustrated at any time.  
 La ACI Srl Farfisa Intercoms se réserve le droit de modifier à tous moments les produits illustrés.

ACI Srl Farfisa intercoms se reserva el derecho de modificar en cualquier momento los productos ilustrados aquí.  
 E' reservada a ACI Srl Farfisa intercoms o direito de modificar a qualquer momento os produtos aqui ilustrados.  
 Änderungen vorbehalten.